



Catálogo Técnico

Sistemas Complementarios

Sistemas complementarios/ índice

Detalle	referencia
Cortina común.....	05
Cortina Barrio.....	06
Tabique tubular.....	07
Tabique liviano A42.....	08
Techo vidriado.....	09
Mampara de baño.....	10
Baranda balcón.....	12
Baranda balcón reforzada.....	15
Parasoles.....	16
Revestimiento y cielorraso.....	20
Frente vidriera.....	22

Sistemas complementarios



Todos los perfiles tienen
Certificación IRAM según
Resolución SCI 158/2018

Prohibida la modificación, publicación o venta, total o parcial de estos documentos, sin la previa autorización por parte de Aluar División Elaborados. Aluar División Elaborados en ningún caso será responsable por los deficientes trabajos ejecutados por terceros en aberturas armadas con nuestros perfiles. Será de exclusiva responsabilidad del instalador, proyectista y/o contratista la previa y correcta verificación estructural de acuerdo a la zona de colocación, exposición y presión de viento, y verificación del balance térmico teniendo en cuenta el tipo de vidrio a utilizar, la temperatura exterior, interior, la humedad relativa, tipo de calefacción, etc.

La empresa se reserva el derecho de modificar total o parcialmente las especificaciones contenidas en este catálogo sin previo aviso.

Este catálogo fue actualizado en Noviembre de 2021.

Sistemas complementarios / cortina común

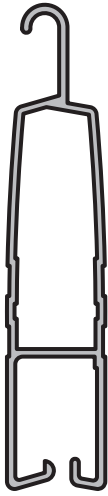

TABLILLA - CORTINA DE ENROLLAR COMUN

Perfil: 5150
Peso: 0,424 Kg/m



ZOCALO - CORTINA DE ENROLLAR COMUN
PARA PERFIL 5150

Perfil: 5169
Peso: 0,753 Kg/m



TABLILLA CORTINA DE ENROLLAR

Perfil: 6307
Peso: 0,418 Kg/m

Sistemas complementarios / cortina barro

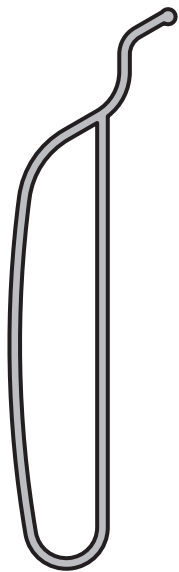

TABLILLA TUBULAR

Perfil: 5423

Peso: 0,545 Kg/m

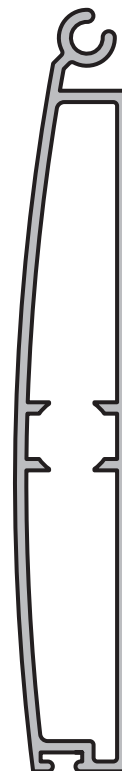

ZOCALO

Perfil: 5550

Peso: 0,958 Kg/m

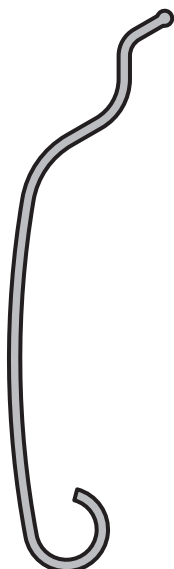

TABLILLA LIVIANA

Perfil: 5425

Peso: 0,400 Kg/m

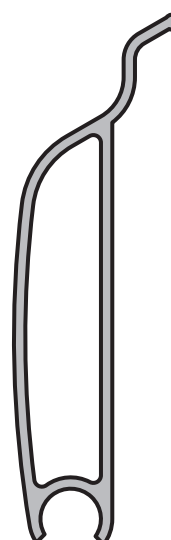

TABLILLA DE COMANDO

Perfil: 5549

Peso: 0,570 Kg/m

Sistemas complementarios / tabique tubular



TAPA ZOCALO
Perfil: 189
Peso: 0,238 Kg/m
Matriz: M2548

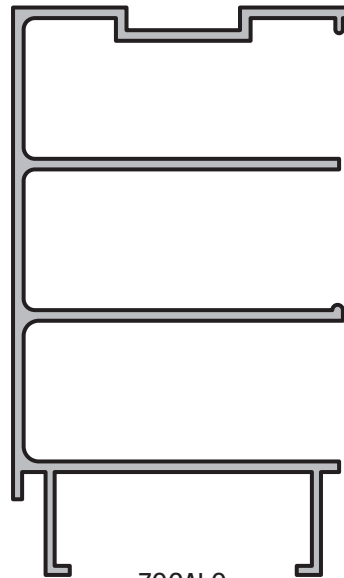

ZOCALO
Perfil: 190
Peso: 1,029 Kg/m
Matriz: M2549



MARCO DE PUERTA
Perfil: 191
Peso: 0,178 Kg/m
Matriz: M2550

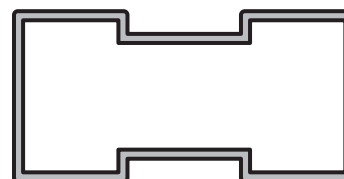

TRAVESAÑO
Perfil: 194
Peso: 0,464 Kg/m
Matriz: M2553



CONTRAVIDRIO LARGO
Perfil: 193
Peso: 0,132 Kg/m
Matriz: M2552

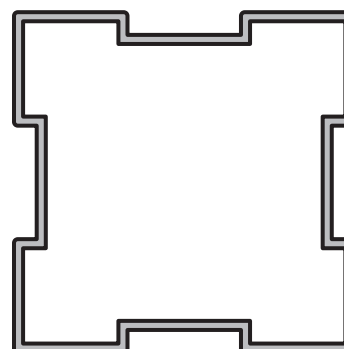

COLUMNA
Perfil: 195
Peso: 0,643 Kg/m
Matriz: M2554



CONTRAVIDRIO CORTO
Perfil: 192
Peso: 0,108 Kg/m
Matriz: M2551

Sistemas complementarios / tabique liviano A42

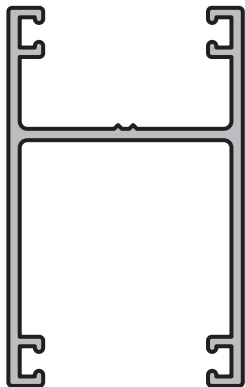

TRAVESAÑO
Perfil: 4361
 Peso: 0,620 Kg/m

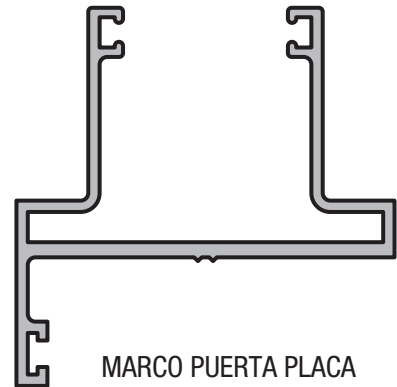

MARCO PUERTA PLACA
Perfil: 4364
 Peso: 0,738 Kg/m



TAPA COLUMNA Y TERMINACION PARED
Perfil: 4362
 Peso: 0,505 Kg/m

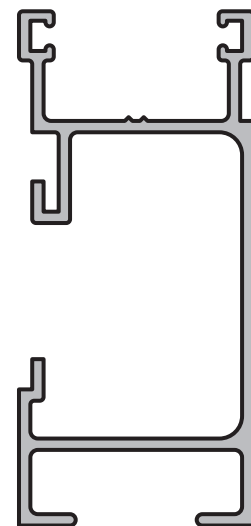

ZOCALO PASACABLE
Perfil: 4365
 Peso: 0,832 Kg/m

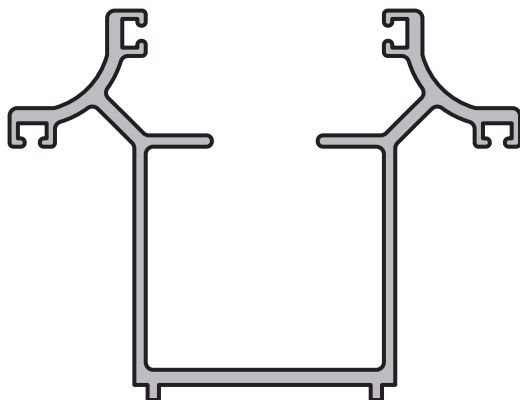

COLUMNA PRINCIPAL
Perfil: 4363
 Peso: 0,988 Kg/m



TAPA ZOCALO
Perfil: 4366
 Peso: 0,204 Kg/m

Sistemas complementarios / techo vidriado

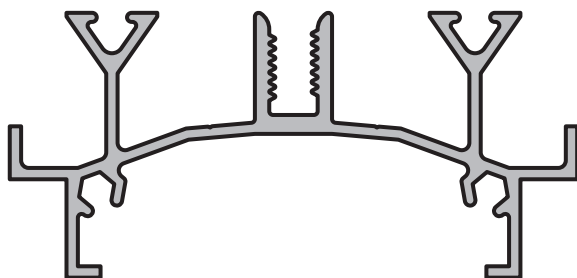

LARGUERO
Perfil: 85
Peso: 1,013 Kg/m
Matriz: M2769



CUBRE TORNILLO
Perfil: 89
Peso: 0,113 Kg/m
Matriz: M2773

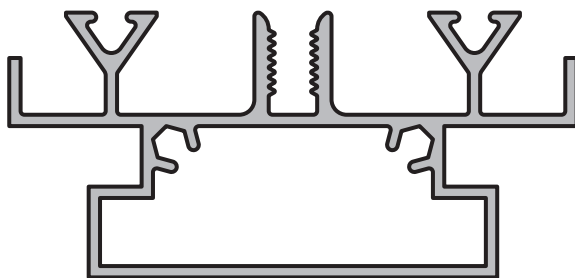

TRAVESAÑO
Perfil: 86
Peso: 1,237 Kg/m
Matriz: M2770



TAPA LARGUERO
Perfil: 87
Peso: 0,486 Kg/m
Matriz: M2771



TAPA TRAVESAÑO
Perfil: 88
Peso: 0,470 Kg/m
Matriz: M2772

Sistemas complementarios / mampara de baño

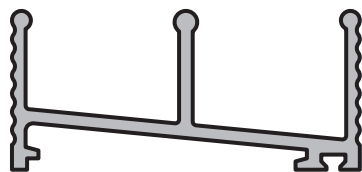

UMBRAL
Perfil: 31
Peso: 0,510 Kg/m
Matriz: M0724

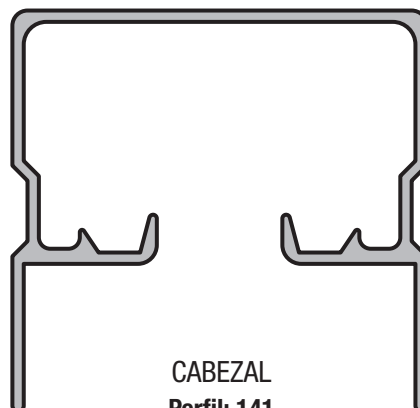

CABEZAL
Perfil: 141
Peso: 0,853 Kg/m
Matriz: M1930



JAMBA
Perfil: 143
Peso: 0,356 Kg/m
Matriz: M1932

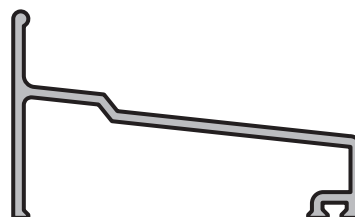

UMBRAL SANITARIO
Perfil: 169
Peso: 0,362 Kg/m
Matriz: M2167

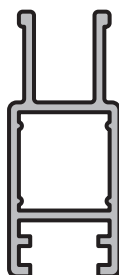

HOJA
Perfil: 144
Peso: 0,362 Kg/m
Matriz: M1933

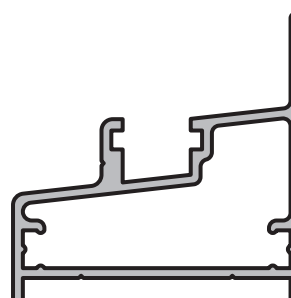

MARCO
Perfil: 188
Peso: 0,545 Kg/m
Matriz: M2463



TOALLERO
Perfil: 147
Peso: 0,273 Kg/m
Matriz: M1984

Sistemas complementarios / mampara de baño

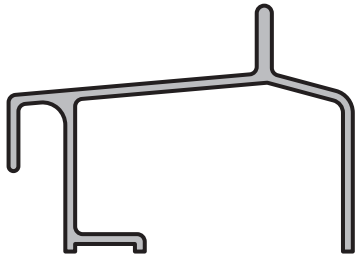

UMBRAL SANITARIO
Perfil: 6926
Peso: 0,419 Kg/m



TRAVESAÑO
Perfil: 6927
Peso: 0,316 Kg/m

Sistemas complementarios / baranda balcón

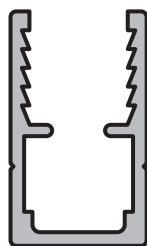

" U " PORTA BLISAN
Perfil: 2441
 Peso: 0,491 Kg/m

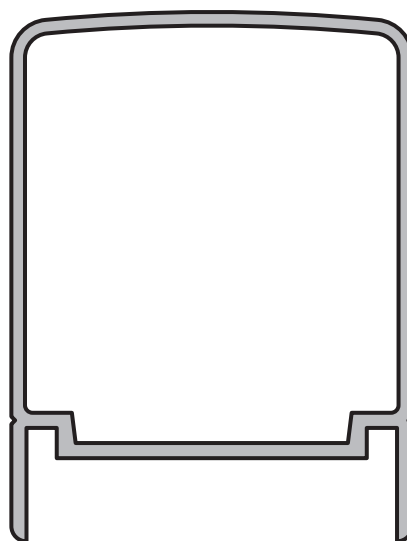

PASAMANOS ALTO
Perfil: 2601
 Peso: 1,264 Kg/m



PASAMANOS ALTO BASE
Perfil: 2603
 Peso: 0,548 Kg/m



PASAMANOS BAJO
Perfil: 2635
 Peso: 0,412 Kg/m

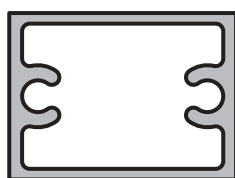

PARANTE ANGOSTO
Perfil: 2633
 Peso: 0,510 Kg/m



TAPA DE LARGUERO
Perfil: 2636
 Peso: 0,343 Kg/m



PASAMANOS BAJO BASE
Perfil: 2634
 Peso: 0,310 Kg/m

Sistemas complementarios / baranda balcón



PARANTE REFORZADO
Perfil: 2637
 Peso: 0,648 Kg/m

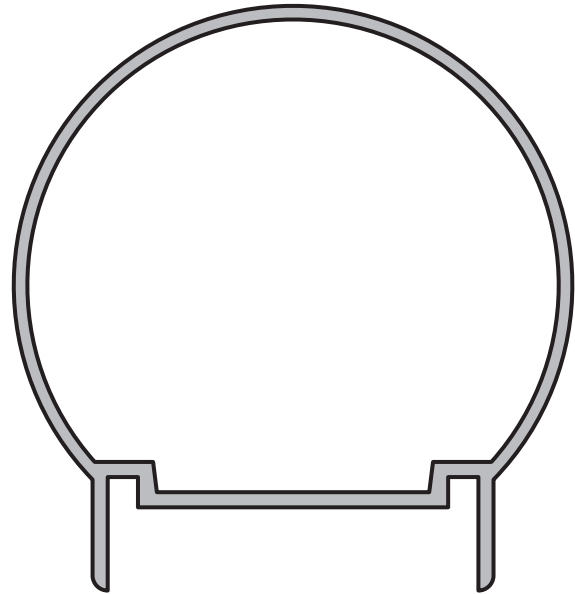

BARANDA TUBULAR
Perfil: 6713
 Peso: 1,303 Kg/m



TAPA PASAMANOS BARANDA PORTA BLISAN
Perfil: 7672
 Peso: 0,297 Kg/m

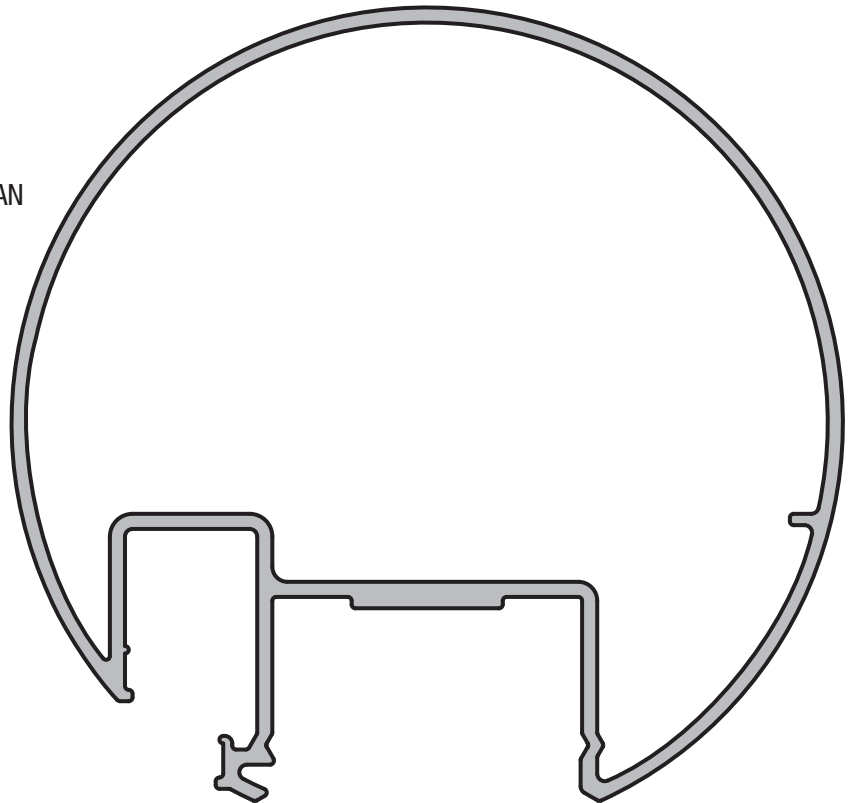

PASAMANOS BARANDA PORTA BLISAN
Perfil: 7673
 Peso: 2,398 Kg/m

Sistemas complementarios / baranda balcón

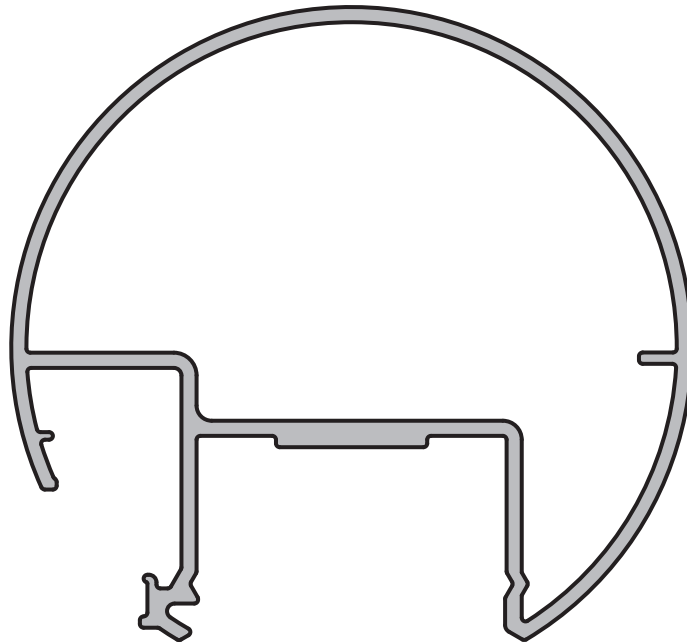

PASAMANOS 90 mm
Perfil 7988
Peso: 1,941 kg/m



PLANCHUELA
Perfil MP-165
Peso: 0,540 kg/m

Sistemas complementarios / baranda balcón reforzada

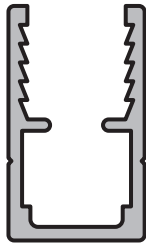

"U" PORTA BLISAN
Perfil 2441
Peso: 0,491 kg/m



PARANTE
Perfil 7947
Peso: 1,172 kg/m

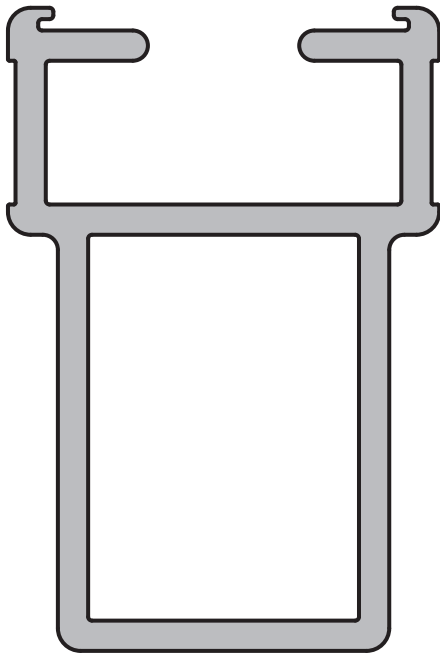

SOPORTE PORTA BLISAN
Perfil 7946
Peso: 3,046 kg/m



TAPA
Perfil 7948
Peso: 0,346 kg/m

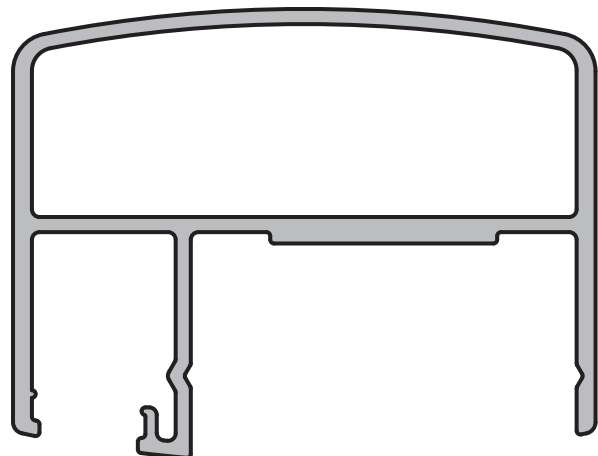

PASAMANOS
Perfil 7949
Peso: 1,810 kg/m



PLANCHUELA
Perfil MP-166
Peso: 0,810 kg/m

Sistemas complementarios / parasoles

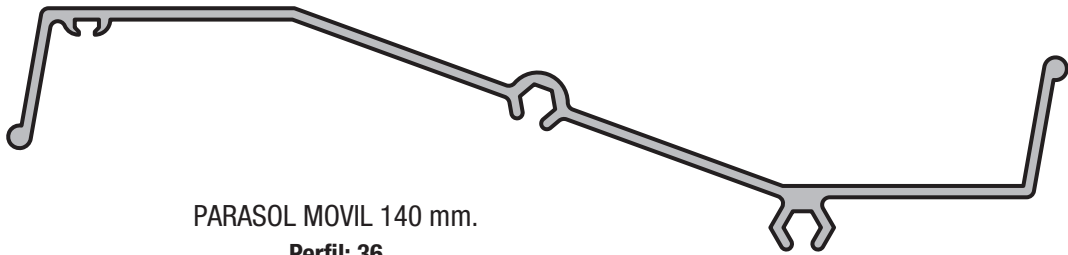

PARASOL MOVIL 140 mm.

Perfil: 36

Peso: 0,832 Kg/m

Matriz: M0729

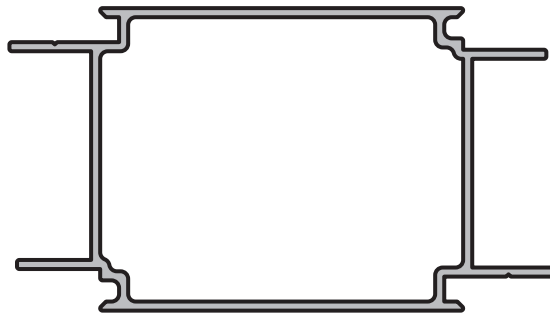

NUCLEO CENTRAL PARASOL

Perfil: 201

Peso: 0,729 Kg/m

Matriz: M2467

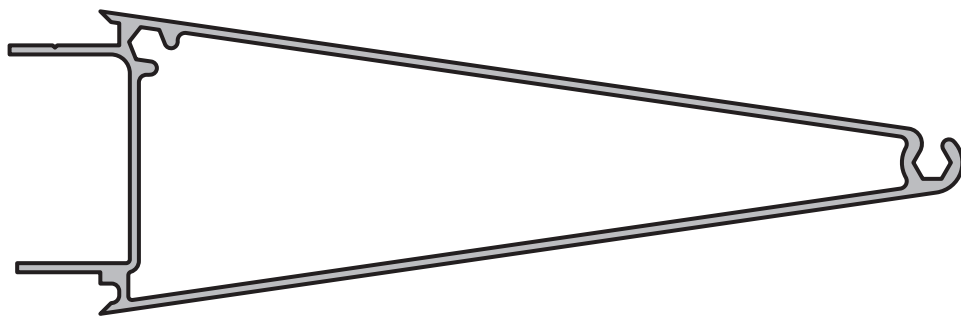

PARASOL MOVIL TUBULAR

Perfil: 202



Peso: 1,048 Kg/m

Matriz: M2533

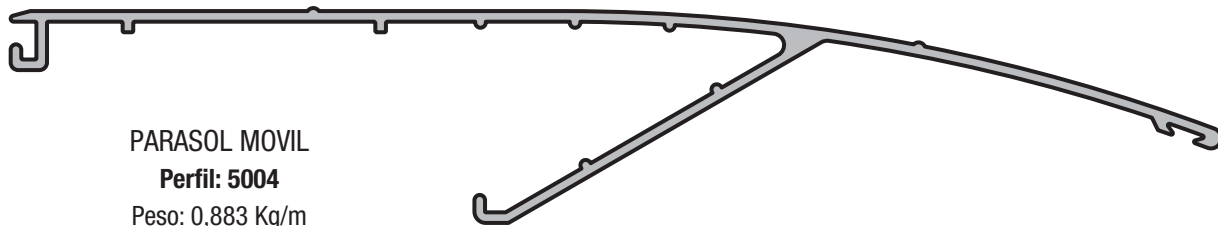
Sistemas complementarios / parasoles

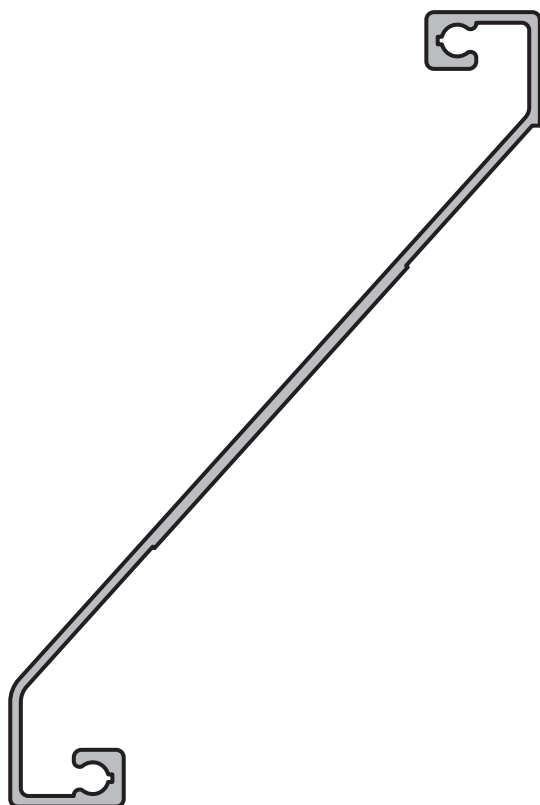

PARASOL MOVIL
Perfil: 5004
Peso: 0,883 Kg/m

PLANCHUELA DE COMANDO
Perfil: 47
Peso: 0,205 Kg/m
Matriz: MP-022

PARASOL DE ALETA FIJA
Perfil: 5650
Peso: 0,780 Kg/m

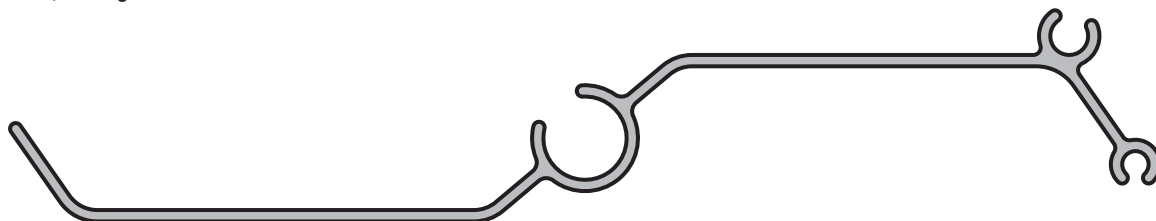

PARASOL MOVIL
Perfil: 5489
Peso: 0,850 Kg/m

Sistemas complementarios / parasoles

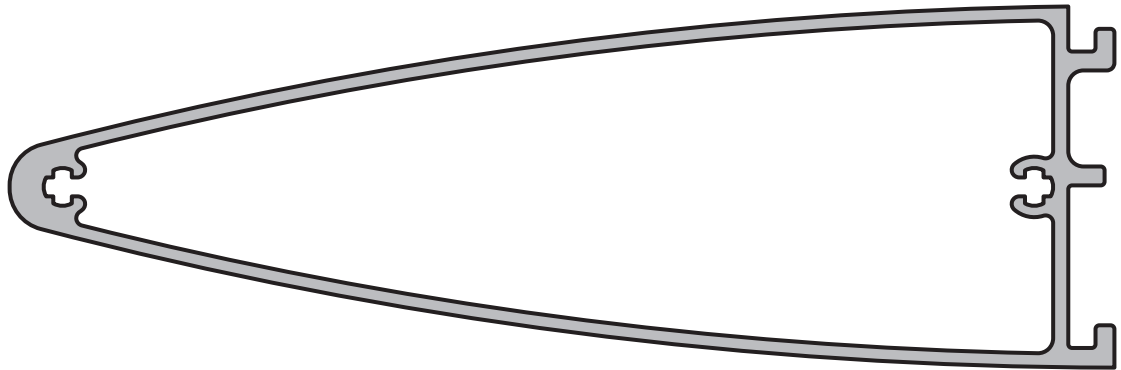

PARASOL PARTE PUNTERA

Perfil: 7257

Peso: 1,968 Kg/m



PARASOL PARTE CENTRAL

Perfil: 7259

Peso: 2,525 Kg/m

Sistemas complementarios / parasoles

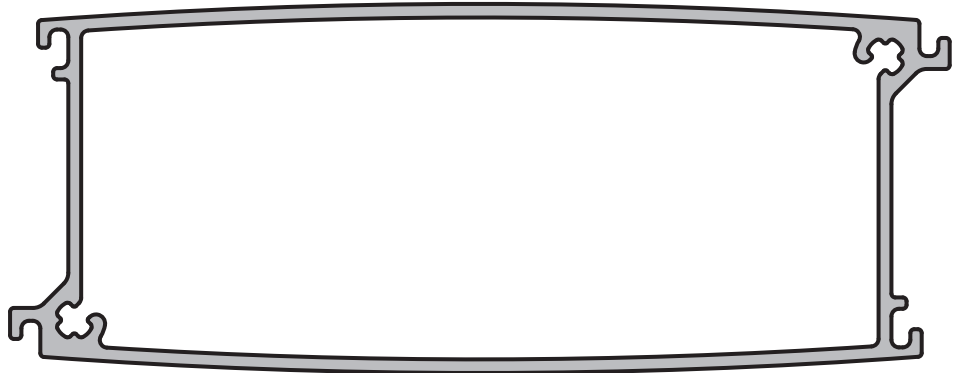

PARASOL PARTE CENTRAL

Perfil 7883

Peso: 1,720 kg/m

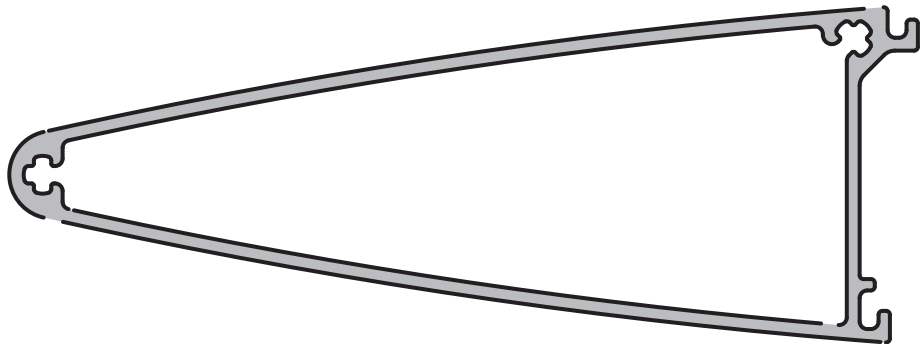

PARASOL PARTE PUNTERA

Perfil 7882

Peso: 1,480 kg/m

Sistemas complementarios / revestimiento y cielorraso

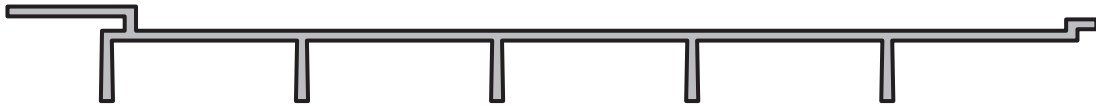

REVESTIMIENTO PEINE

Perfil: 683

Peso: 0,710 Kg/m

Matriz: M1696



REVESTIMIENTO LIVIANO

Perfil: 688

Peso: 0,340 Kg/m

Matriz: M1803



REVESTIMIENTO DOBLE FAZ

Perfil: 5701

Peso: 0,656 Kg/m

Sistemas complementarios / revestimiento y cielorraso



REVESTIMIENTO TUBULAR LISO

Perfil: 5726

Peso: 0,862 Kg/m



REVESTIMIENTO TUBULAR 7 mm.

Perfil: 6428

Peso: 0,597 Kg/m



SIMULACION PLACA - BASE

Perfil: 6488

Peso: 0,116 Kg/m



SIMULACION PLACA - TAPA ROMBO

Perfil: 6489

Peso: 0,164 Kg/m



SIMULACION PLACA - TAPA CURVA

Perfil: 6785

Peso: 0,168 Kg/m

Sistemas complementarios / frente vidriera

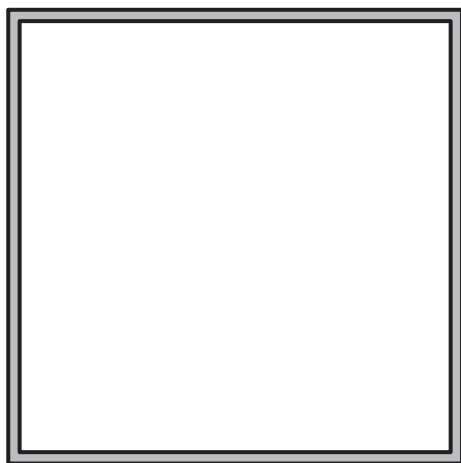

TUBO CUADRADO 60 x 1,5 mm.

Perfil: MC-143

Peso: 0,948 Kg/m



TUBO RECTANGULAR 60 x 25 x 1,5 mm.

Perfil: MC-080

Peso: 0,664 Kg/m

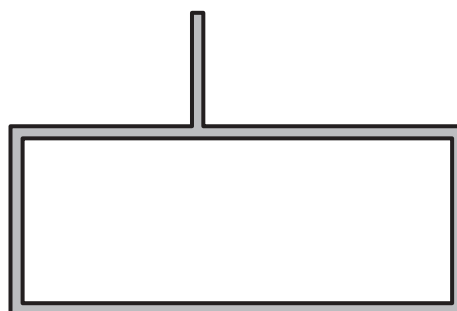

TUBO RECTANGULAR CON UNA ALETA DE 60 x 25 x 1,6 mm.

Perfil: 2674

Peso: 0,770 Kg/m

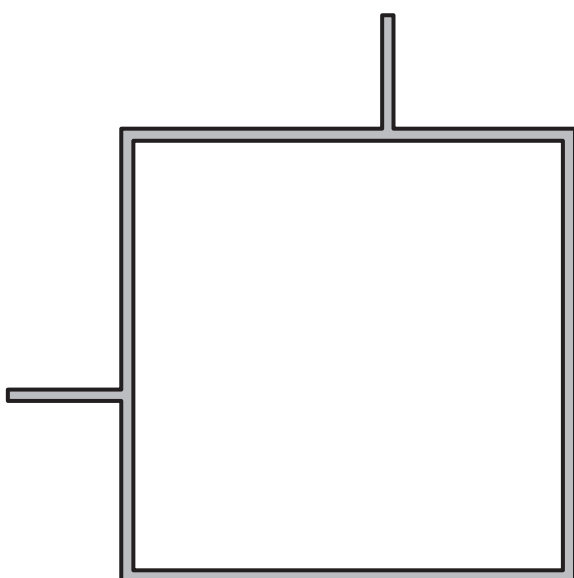

TUBO CUADRADO CON DOS ALETAS DE 60 x 1,6 mm.

Perfil: 2707

Peso: 1,131 Kg/m

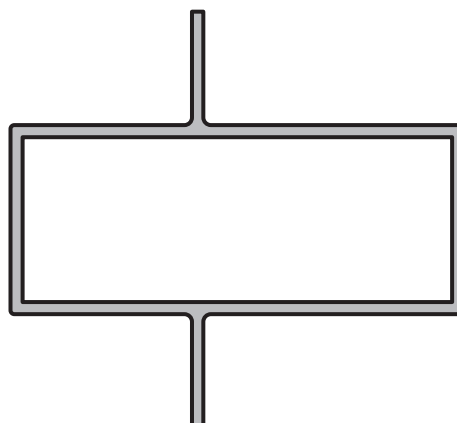

TUBO RECTANGULAR CON DOS ALETAS DE 60 x 25 x 1,6 mm.

Perfil: 3994

Peso: 0,834 Kg/m

Sistemas complementarios / frente vidriera



CANAL DE 60 x 25 x 1,6 mm.

Perfil: 2610

Peso: 0,535 Kg/m

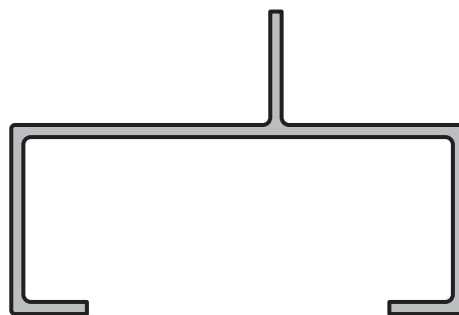

CANAL CON UNA ALETA DE 60 x 25 x 1,6 mm.

Perfil: 3993

Peso: 0,594 Kg/m

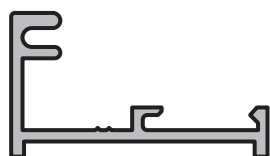

PORTACONTRAVIDRIO UNIVERSAL SIMPLE

Perfil: 52

Peso: 0,300 Kg/m

Matriz: M0947



PORTACONTRAVIDRIO CON ALETA, CLIPA CON N 8

Perfil: 6924

Peso: 0,186 Kg/m



PORTACONTRAVIDRIO SIMPLE, CLIPA CON N 8

Perfil: 6925

Peso: 0,132 Kg/m

Sistemas complementarios / frente vidriera

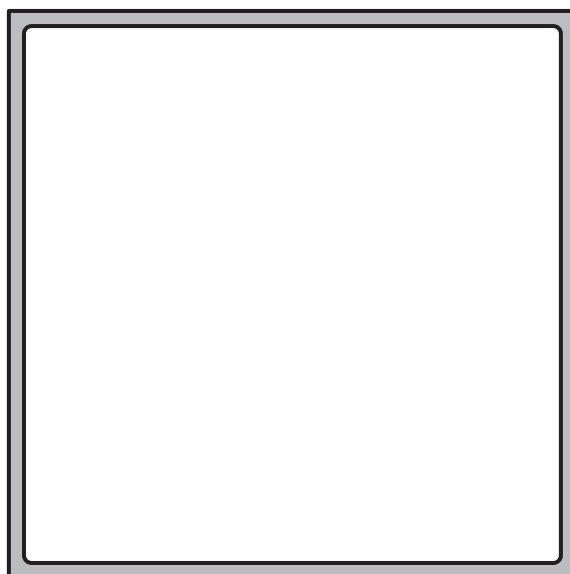

TUBO CUADRADO 75 x 2 mm.

Perfil: 3109

Peso: 1,580 Kg/m

Matriz: PC3109

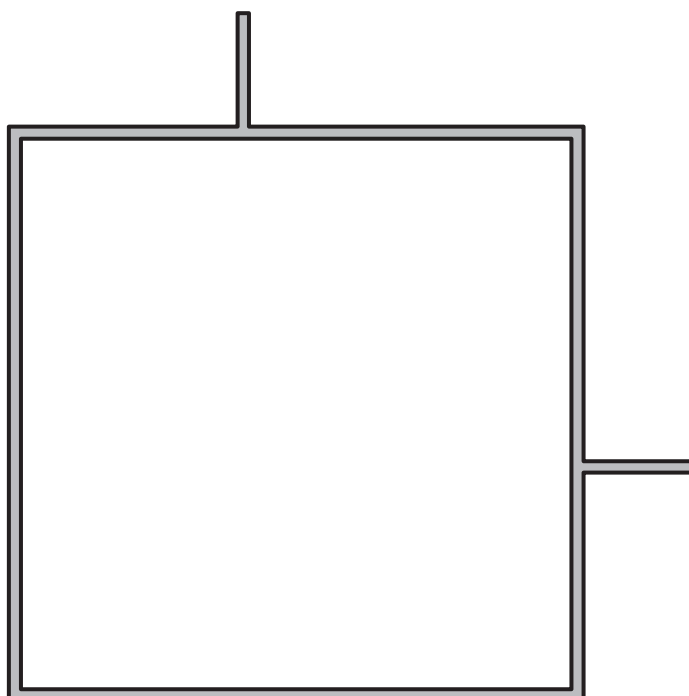

TUBO CUADRADO CON DOS ALETAS DE 76 x 1,6 mm.

Perfil: 2708

Peso: 1,407 Kg/m

Sistemas complementarios / frente vidriera



TUBO RECTANGULAR 76 x 25 x 1,6 mm.

Perfil: 3988
 Peso: 0,845 Kg/m
 Matriz: PC3988



CANAL DE 76 x 25 x 1,6 mm.

Perfil: 3992
 Peso: 0,605 Kg/m

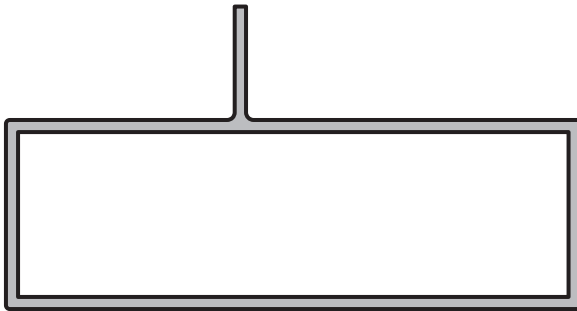

TUBO RECTANGULAR CON UNA ALETA 76 x 25 x 1,6 mm.

Perfil: 3989
 Peso: 0,905 Kg/m

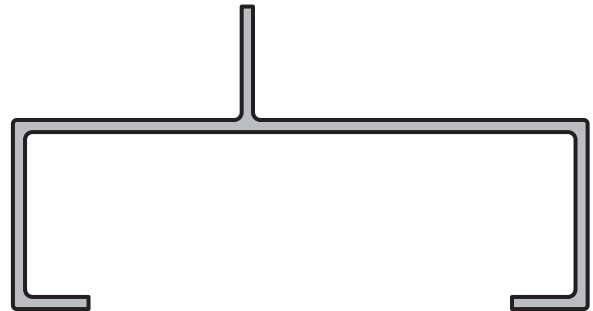

CANAL CON UNA ALETA 76 x 25 x 1,6 mm.

Perfil: 3991
 Peso: 0,664 Kg/m

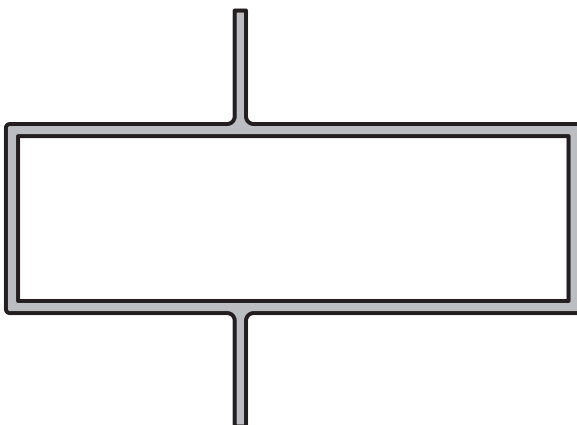

TUBO RECTANGULAR CON DOS ALETAS 76 x 25 x 1,6 mm.

Perfil: 3990
 Peso: 0,967 Kg/m

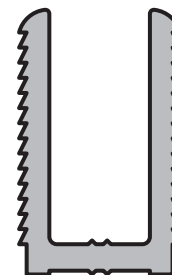

U DE ARMADO SERIES 60 x 25 y 76 x 25 mm.

Perfil: 3024
 Peso: 0,767 Kg/m

Sistemas complementarios / frente vidriera

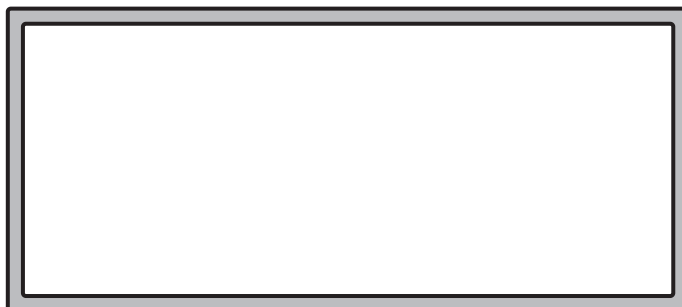

TUBO RECTANGULAR 90 x 40 x 2 mm.

Perfil: 4833

Peso: 1,361 Kg/m

Matriz: PC4833

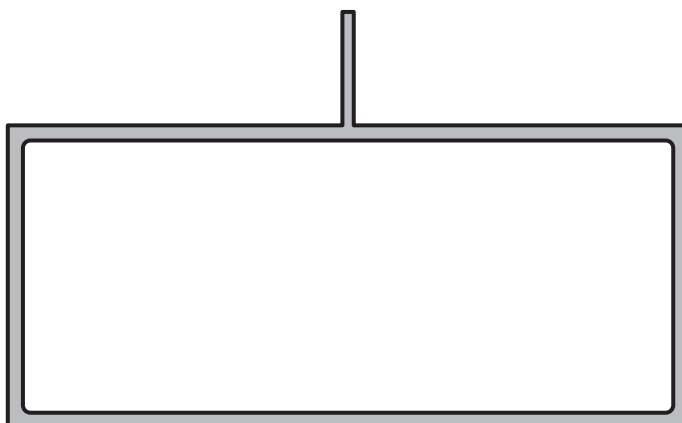

TUBO RECTANGULAR CON UNA ALETA DE 90 x 40 x 2 mm.

Perfil: 5311

Peso: 1,420 Kg/m

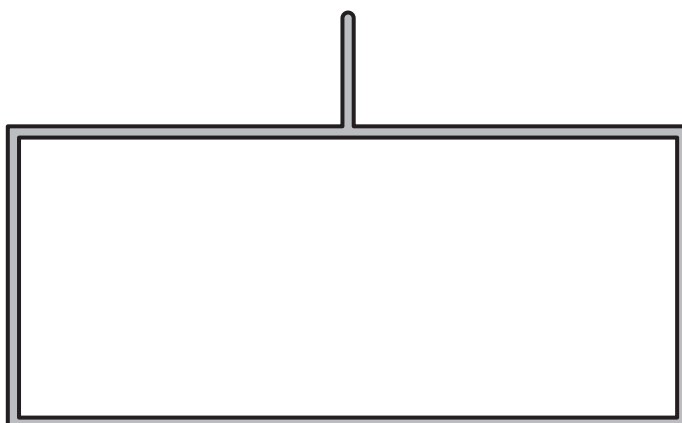

TUBO RECTANGULAR CON UNA ALETA 90 x 40 x 1,5 mm.

Perfil: 492

Peso: 1,080 Kg/m

Matriz: M1980

Sistemas complementarios / frente vidriera

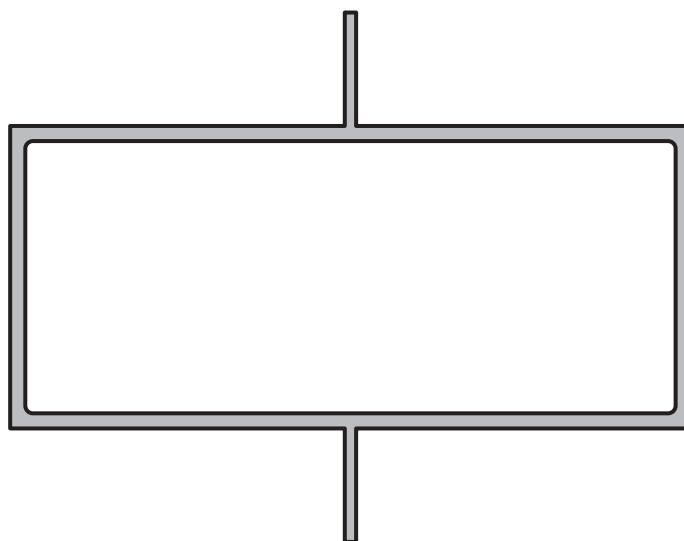

TUBO RECTANGULAR CON DOS ALETAS DE 90 x 40 x 2 mm.

Perfil: 5312

Peso: 1,479 Kg/m

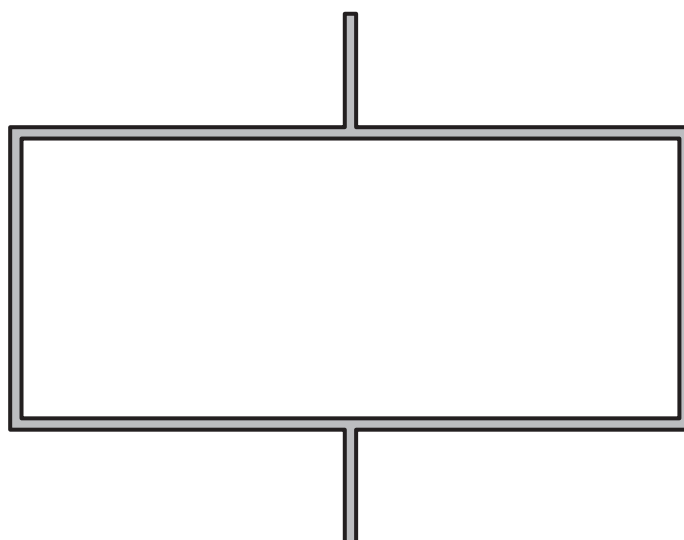

TUBO RECTANGULAR CON DOS ALETAS 90 x 40 x 1,5 mm.

Perfil: 493

Peso: 1,150 Kg/m

Matriz: M1981

Sistemas complementarios / frente vidriera



CANAL DE 90 x 40 x 2 mm.

Perfil: 4834

Peso: 0,982 Kg/m

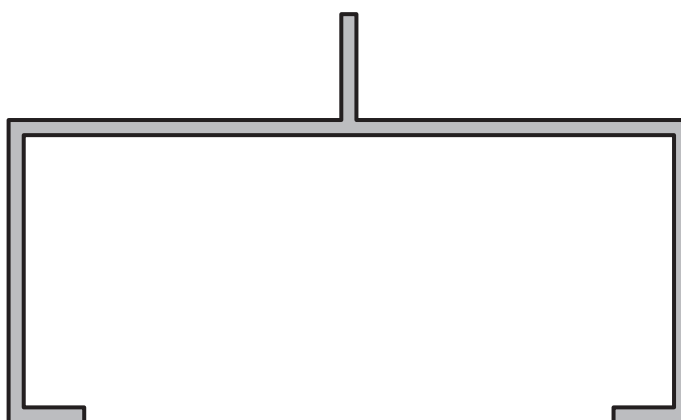

CANAL CON UNA ALETA DE 90 x 40 x 2 mm.

Perfil: 5310

Peso: 1,042 Kg/m



SEMITUBO PARA CUADRADO DE 90 x 90 mm.

Perfil: 2719

Peso: 1,104 Kg/m

Sistemas complementarios / frente vidriera

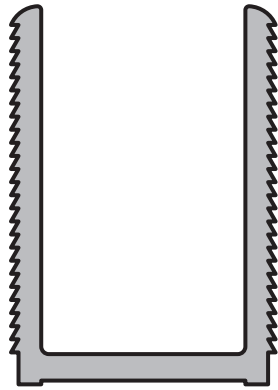

U DE ARMADO SERIE 90 x 40 x 2 mm.
Perfil: 3022
Peso: 1,188 Kg/m

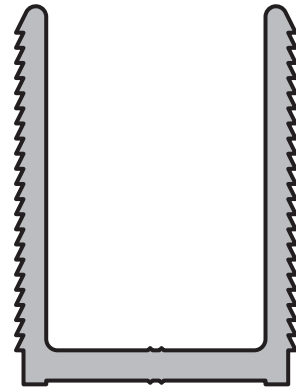

U DE ARMADO SERIE 90 x 40 x 1,5 mm.
Perfil: 494
Peso: 1,237 Kg/m
Matriz: M1982

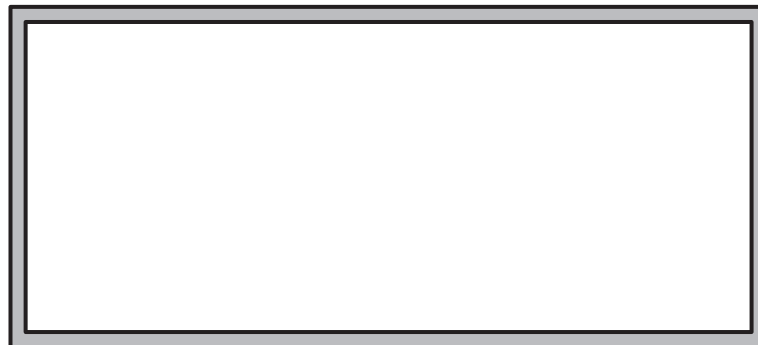

TUBO RECTANGULAR 100 x 45 x 2 mm.
Perfil: 4836
Peso: 1,523 Kg/m
Matriz: PC4836

Sistemas complementarios / frente vidriera

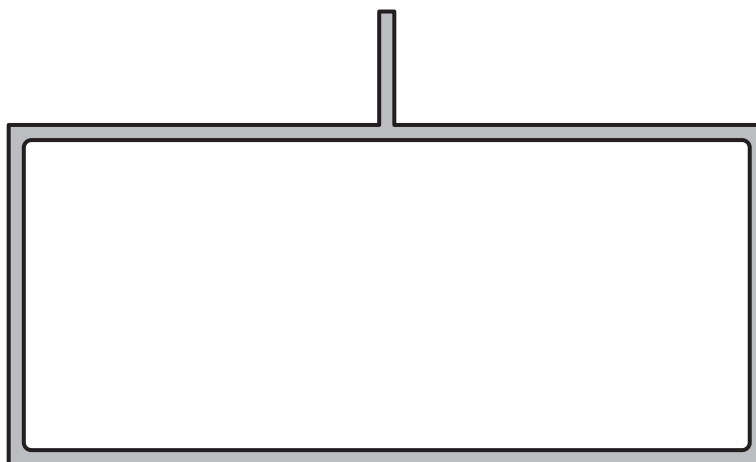

TUBO RECTANGULAR CON UNA ALETA DE 100 x 45 x 2 mm.

Perfil: 5316

Peso: 1,603 Kg/m

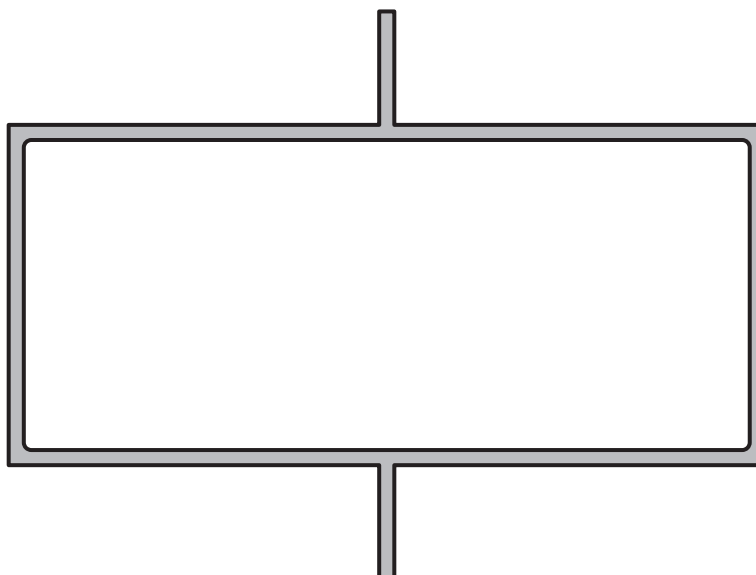

TUBO RECTANGULAR CON DOS ALETAS DE 100 x 45 x 2 mm.

Perfil: 5317

Peso: 1,684 Kg/m

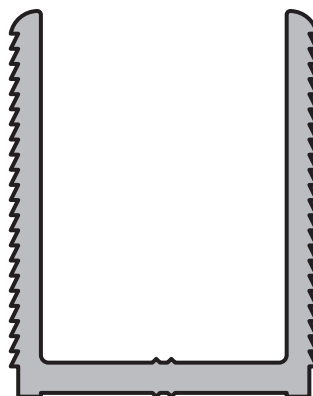

U DE ARMADO SERIE 100 x 45 x 2 mm.

Perfil: 3046

Peso: 1,258 Kg/m